



- Bridge Testing & Rating Services
- Structural Testing Equipment
- Long-Term Monitoring
- Fatigue Monitoring Systems

## BDI Strain Transducer ST-350

The most direct approach to quantifying live-load stresses in a structural member is to record the induced strains. However, it can be tedious work to install foil strain gages since careful surface preparation and soldering is often required. Now, many traditional strain gage installations can be replaced with the highly accurate BDI Strain Transducer. These units are rugged and can be installed in any weather. Since they are pre-wired and easy to mount, BDI Strain Transducers will drastically reduce your testing time!

### Highlights

- Very cost effective
- Install in 5 minutes or less
- Completely reusable - never wears out!
- Water and weather resistant
- Custom cable types and lengths available
- Compatible with most data acquisition systems
- The BDI Strain Transducer was one of **Sensors Magazine's 50 Top Products of 2006!**

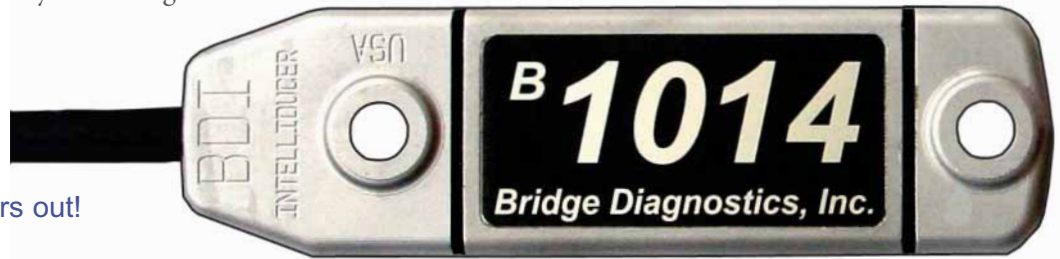

BDI Intelliducer



Girders



Reinforced Concrete



Trusses

### Many Applications

Measure strains on highway bridges, railroad bridges, navigation lock gates, amusement park rides, and other structures in which a short-term live-load can be easily applied. Also excellent for many laboratory tests and manufacturing processes. The BDI Strain Transducers have been successfully used for measurements on:

- Steel Structures
- Post-tensioned and pre-stressed concrete structures
- Reinforced concrete structures
- Timber structures
- Fiber reinforced polymer structures

### Key Features

- **Easy Installation:** Attaches to all types of structural members in about five minutes each. Instrument and test with 64 strain channels in one day!
- **High Output:** Provides approximately 3 times the output as a typical quarter-arm foil gage installation. This improved signal-to-noise ratio means higher-resolution measurements.
- **Excellent Compatibility:** The BDI Strain Transducers can be used with most data acquisition systems that support full-bridge type sensors, or with our specially-designed BDI Structural Testing System (BDI-STs).
- **Very Cost-Effective:** Due to their complete re-usability and the extensive reduction in installation time, the BDI Strain Transducers will pay for themselves with just a few uses.
- **Field Proven:** These sensors have been used over the last two decades for recording millions of strain measurements on all types of structures, often in harsh field conditions.

# BDI Strain Transducer ST-350

## Options and Accessories

Bridge Diagnostics, Incorporated  
1965 57th Court North, Suite 106  
Boulder, CO 80301-2826 USA  
www.bridgetest.com  
303.494.3230

**BDI**  
Bridge Diagnostics Inc  
"We stand below our work"

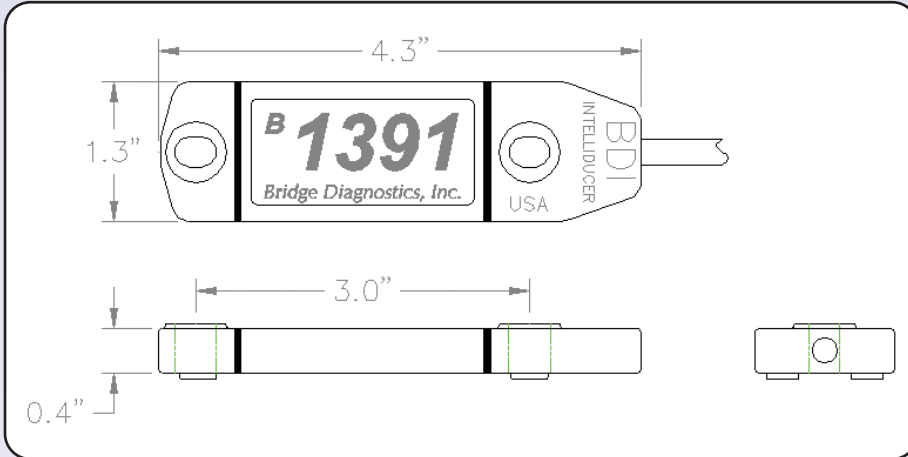

*BDI transducers have a 3" gage length*



*Strain transducers are supplied as standard equipment with BDI Structural Testing Systems*



*Gage extensions for measuring "averaged" strains on reinforced concrete members*



*Rugged aluminum covers protect transducers for long-term monitoring*

### Technical Specifications

Effective gage length	3.0 in (76.2 mm). Extensions available for use on R/C structures
Overall Size	4.375 in x 1.25 in x 0.5 in (111 mm x 32 mm x 13 mm)
Cable Length	10 ft (3 m) standard, any length available
Material	Aluminum
Circuit	Full wheatstone bridge with 4 active 350W foil gages, 4-wire hookup
Accuracy	± 2%, individually calibrated to NIST standards
Strain Range	Aluminum: ±4000 $\mu\epsilon$
Force required for 1000 $\mu\epsilon$ :	Approximately 17 lbs. (76 N)
Sensitivity	Approximately 500 $\mu\epsilon$ /mV/V
Weight	Approximately 3 oz. (85 g)
Environmental	Built-in protective cover, also water resistant
Temperature Range	-60°F to 250°F (-50°C to 120°C ) operation range
Cable	BDI RC-187: 22 gage, two individually-shielded pairs w/drain
Attachment Methods	Mounting tabs & adhesive, C-Clamps, masonry or wood screws



*Mounting tabs and tab jig*



*BDI Strain Transducer cable options*